

4

3

2

1

| REVISIONS | | | | |
|-----------|------|-----------------|-----------|----------|
| ZONE | REV. | DESCRIPTION | DATE | APPROVED |
| | A | INITIAL RELEASE | 6/14/2023 | J.FERDEN |

B

B

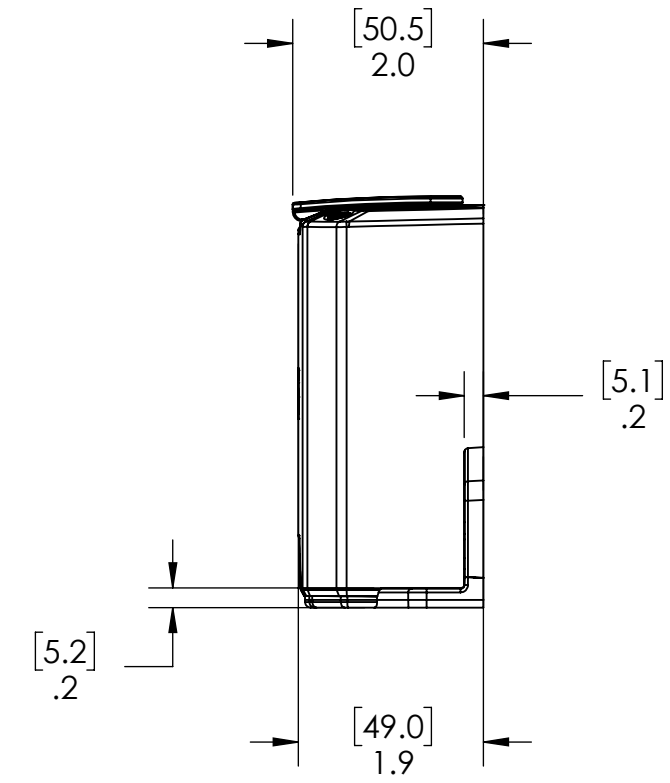
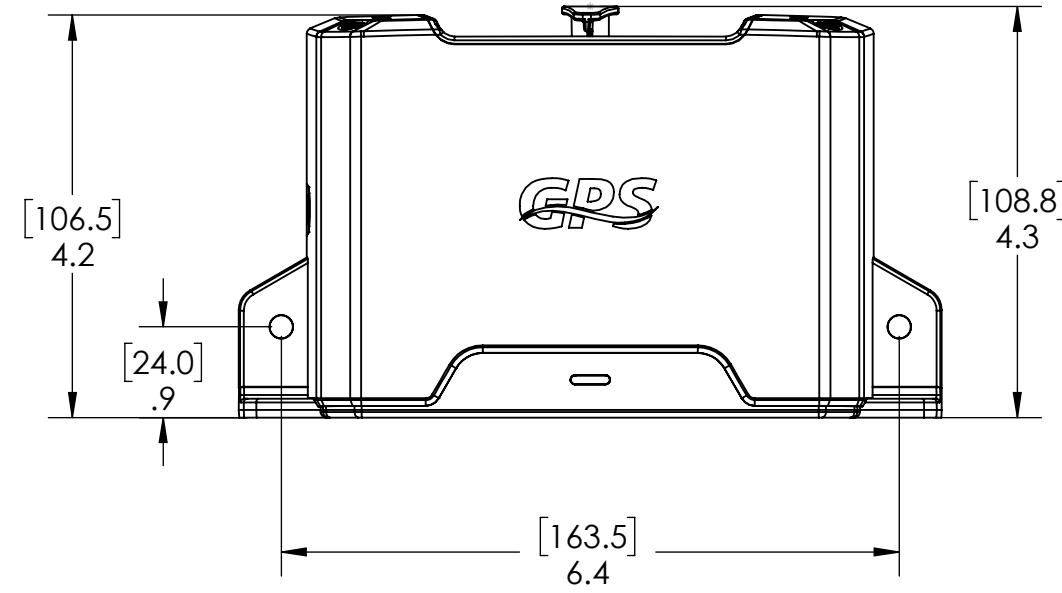

A

A

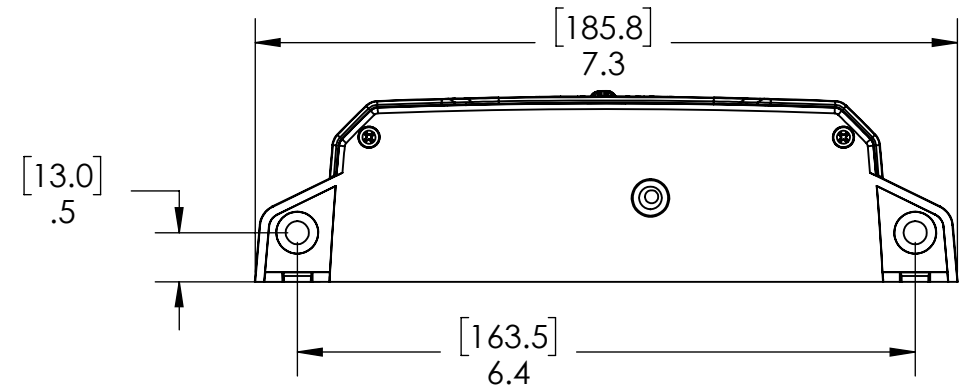

PROPRIETARY AND CONFIDENTIAL
 THE INFORMATION CONTAINED IN THIS DRAWING IS THE SOLE PROPERTY OF GLOBAL PLASMA SOLUTIONS. ANY REPRODUCTION IN PART OR AS A WHOLE WITHOUT THE WRITTEN PERMISSION OF GLOBAL PLASMA SOLUTIONS IS PROHIBITED.

| | | | | | |
|---|-----------------------------|----------------------|-----------|------|-----------------------|
|  | UNLESS OTHERWISE SPECIFIED: | | NAME | DATE | TITLE: PF-I |
| | DIMENSIONS ARE IN MM | | DRAWN | | |
| | TOLERANCES: | | CHECKED | | |
| | ANGULAR: ±0.5 | | ENG APPR. | | |
| ONE PLACE DECIMAL ±0.25 | | MFG APPR. | | | |
| TWO PLACE DECIMAL ±0.13 | | Q.A. | | | |
| INTERPRET GEOMETRIC TOLERANCING PER: ASME Y14.5 | | COMMENTS: | | | |
| MATERIAL | | | | | |
| FINISH | | | | | |
| NEXT ASSY | USED ON | | | | |
| APPLICATION | | DO NOT SCALE DRAWING | | | |

| | | |
|------------|----------------|--------------|
| SIZE | PART NUMBER | REV |
| B | GPS-046 | A |
| SCALE: 1:2 | WEIGHT: | SHEET 1 OF 1 |

4

3

2

1