

4

3

2

1

REVISIONS				
ZONE	REV.	DESCRIPTION	DATE	APPROVED
	A	INITIAL RELEASE	6/14/2023	J.FERDEN

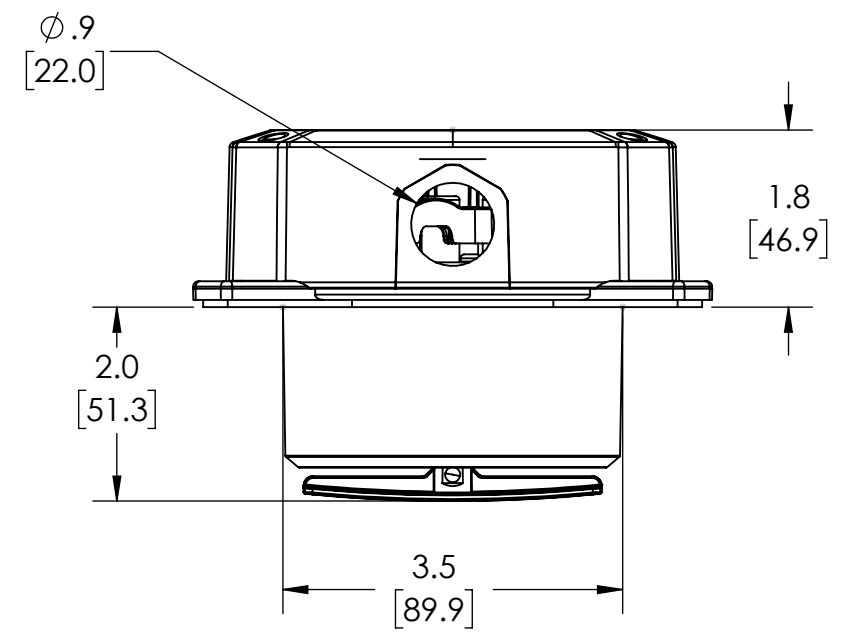
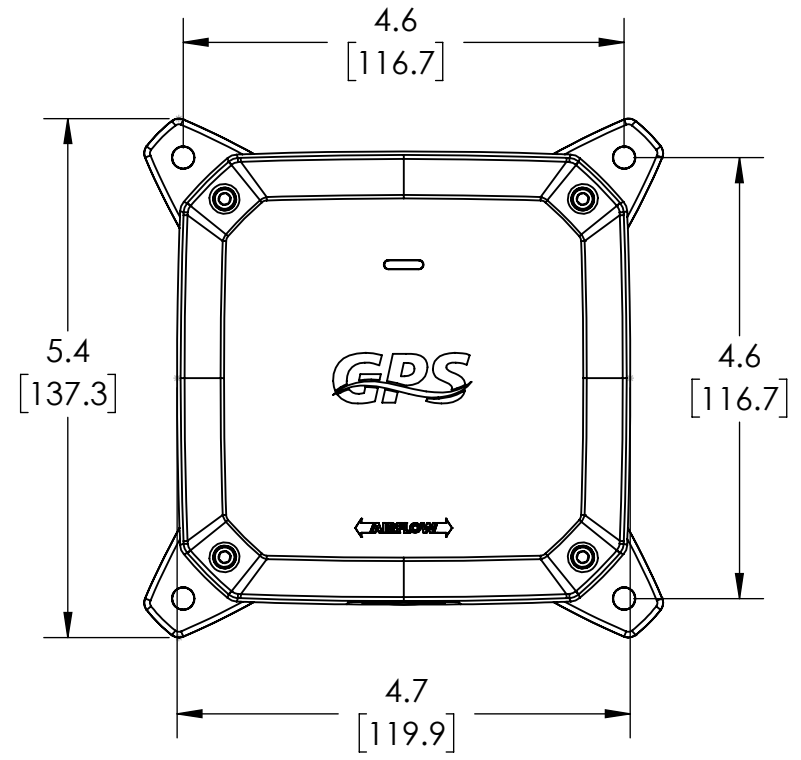

**PROPRIETARY AND CONFIDENTIAL**  
 THE INFORMATION CONTAINED IN THIS DRAWING IS THE SOLE PROPERTY OF GLOBAL PLASMA SOLUTIONS. ANY REPRODUCTION IN PART OR AS A WHOLE WITHOUT THE WRITTEN PERMISSION OF GLOBAL PLASMA SOLUTIONS IS PROHIBITED.

	UNLESS OTHERWISE SPECIFIED:		NAME	DATE	TITLE:  <h1>PF-E</h1>
	DIMENSIONS ARE IN MM		DRAWN		
	TOLERANCES:		CHECKED		
	ANGULAR: ±0.5		ENG APPR.		
ONE PLACE DECIMAL ±0.25		MFG APPR.			
TWO PLACE DECIMAL ±0.13		Q.A.			
INTERPRET GEOMETRIC TOLERANCING PER: ASME Y14.5		COMMENTS:			
MATERIAL					
FINISH					
NEXT ASSY	USED ON				
APPLICATION		DO NOT SCALE DRAWING			

SIZE	PART NUMBER	REV
<b>B</b>	<b>GPS-045</b>	<b>A</b>
SCALE: 1:5	WEIGHT:	SHEET 1 OF 1

4

3

2

1

B

B

A

A