

*Installation, Operation & Maintenance Manual*

# GPS-iMOD<sup>®</sup>

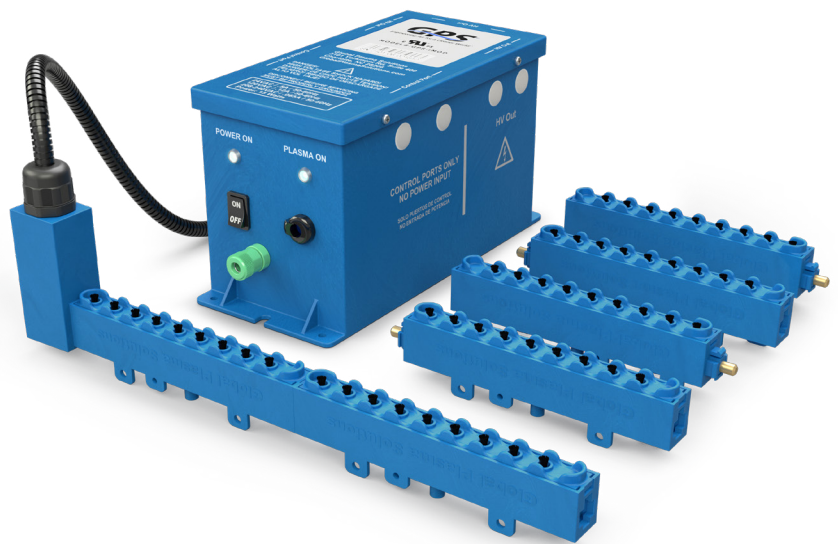

NOTICE: This product is to be used only as directed. Read entire manual before use. Do not use unless properly installed.



# Table of Contents

<i>Hardware Required and Installation Location</i> .....	1
<i>Mechanical Installation</i> .....	2-5
<i>iMOD Mounting</i> .....	6-7
<i>Connection of GPS-iMOD bars to Power Supply</i> .....	8
<i>Power Supply Installation and Wiring</i> .....	9-11
<i>Connecting to GPS-iDETECT-P</i> .....	11
<i>Operation</i> .....	12
<i>Start Up/Testing</i> .....	12
<i>Product Registration</i> .....	12
<i>Start-Up/Maintenance</i> .....	12
<i>Troubleshooting</i> .....	13

## *Startup/Testing*

Please consult and complete the GPS Air 'GPS-iMOD startup checklist', which can be found on our website or by utilizing the QR code below.



[gpsair.com](http://gpsair.com)

Thank you for purchasing a GPS-iMOD® air ionization system from GPS Air.

### *Hardware Provided by GPS*

Before you start, confirm the contents of your shipment contains all the parts ordered. Each GPS-iMOD system will consist of the following components:

1. GPS-iMOD 15-watt power supply with multi-voltage input: (24VAC/0.5A; 120VAC/0.12A; 208-240VAC/0.065A).
2. GPS-iMOD 6' and/or 15' flexible high voltage cables with connectors and first electrode on the bar already attached. More than 1 high voltage cable may be provided based on the application and cooling coil dimensions.
3. GPS-iMOD 6-inch modular sections provided per quantities ordered to achieve overall ionization bar length.
4. End cap for each iMOD assembly bar. End cap inserts into the last modular section of the bar to prevent contamination.
5. Mounting magnets per 18" of bar length. Magnets are used for securing the GPS-iMOD to the cooling coil inlet on the downstream side of the filter rack. Magnet quantity provided will increase based on overall bar length. Refer to iMod Mounting section for recommended magnet spacing.
6. Nylon screws and nuts for securing magnets to the front or back of the iMOD sections and metal screws for securing magnets to the top of the iMOD sections where the bar can be mounted to the ceiling of an air handler.
7. Stand-offs for elevating HV cable above mounting surface
8. Nylon cable ties for use with stand-offs

Optional accessories may be included based on the items quoted or provided in the purchase order:

1. Remote mounted ion sensor(s)
2. NEMA 4x enclosure for power supply

### *Hardware Required by Others*

1. Self-tapping sheet metal screws for iMOD system components. #8 size screws are to be used. Additionally, the screws should be of adequate material, length and thread thickness to avoid corrosion, fit through magnet (spacer) and support the iMOD bar to the Ground Reference mounting surface. Care should be taken when selecting self tapping screws to avoid penetrating the cooling coil.
2. Electric wiring, junction box or receptacle to provide power to the GPS-iMOD power supply, optional door switch.
3. Grommets for any penetrations

### *Installation Location*

The optimal location to mount the GPS-iMOD is on the air entering side of the cooling coil, downstream of the filter.



**CAUTION: MAKE SURE POWER IS DISCONNECTED TO THE HVAC EQUIPMENT BEFORE INSTALLATION**



## Mechanical Installation

The GPS-iMOD bar(s) should be spaced a maximum of 60 inches apart for appropriate ionization coverage on a single coil. iMOD bar shall cover the entire finned length of coil to the nearest 6" without exceeding the length of the coil. (see FIGURE 13).

### Step 1 - Determine which style of GPS-iMOD is being installed.

- i. If using the snap-type iMOD, go to Step 1A (Refer to FIGURE 2 for GPS-iMOD snap-type without threads).
- ii. If using the screw-type iMOD, go to Step 1B (Refer to FIGURE 1 for GPS-iMOD screw-type with threaded post).



Figure 1

Figure 2

### Step 1A – Assembly of snap-type GPS-iMOD

Once the mounting location has been verified, assemble the modular sections by inserting the post-end of the iMOD into the receiver-end of the first modular section already attached to the powerhead (see FIGURE 3). Attach iMOD sections, making sure they are properly aligned as shown in FIGURE 4. Attach the iMOD sections by using a rubber mallet and carefully tapping with enough force to cause the modular sections to “snap” together (see FIGURE 5). Secure iMOD firmly while tapping with mallet to avoid slipping.

***Do not hold iMOD between modules while assembling to avoid pinch hazard.***

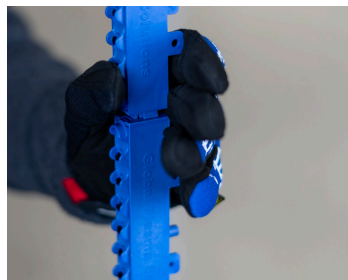

Improper Grip - Pinch Hazard

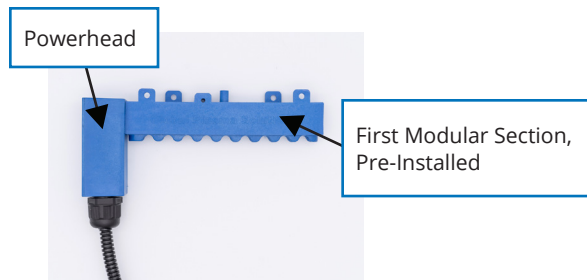

Figure 3

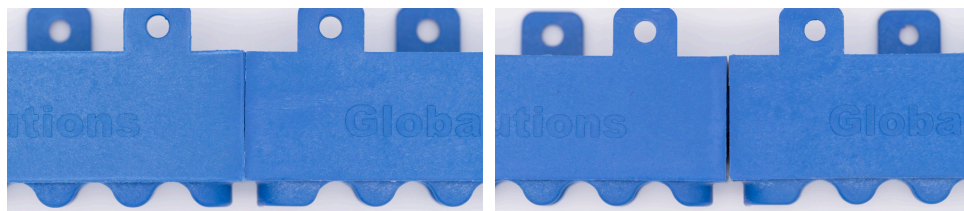

Figure 4A - Proper assembly - no gap

Figure 4B - Improper assembly - gap present





Figure 5





**CAUTION:** Once iMOD modules are snapped together, they cannot be disassembled. Doing so will cause irreparable non-visible damage and void warranty.

Continue assembling the modular sections until you reach the needed length for the coil. After assembling the first 8 iMOD sections, lay the assembly on floor with the powerhead firmly butted against a rigid wall. See FIGURE 6. Continue to add iMOD sections until you reach the required length of the assembly. Proceed to STEP 2.



Figure 6

### Step 1B – Assembly of screw-type GPS-iMOD

Once the mounting location has been verified, assemble the modular sections by inserting the male threaded post into the female receiver of the first modular section already attached to the powerhead (see FIGURE 7) and tighten until the modular housings are securely butted to each other. See FIGURE 8 below for correct assembly alignment. Please note, it should take 3-4 complete revolutions to assemble properly. Continue process until all modules are assembled to the desired length of the bar.

Not all the bars will screw together and line up with the brushes pointing in the same direction without using excessive force that could damage the module. Below are directions to assemble the bars to ensure alignment.

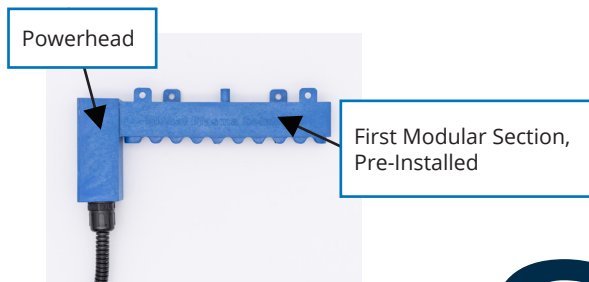

Figure 7



Figure 8A - Proper - no gap



Figure 8B - Proper, small gap, filled by washer



Figure 8C - Improper, big gap



## iMOD ALIGNMENT

When the sections do not align properly after they have been securely adjusted, as shown in FIGURE 9, disassemble the section and place nylon spacer(s) provided by GPS between the two sections as shown in FIGURE 10. Use several if needed.

Once the spacer is placed over the male end of the device, twist the modules together until the parts are snug, and the carbon fiber brushes are pointing in the same direction, as shown in FIGURE 8A or 8B. Please note, once the bars are assembled, there should be no “wobble” between the sections. Proceed to Step 2.

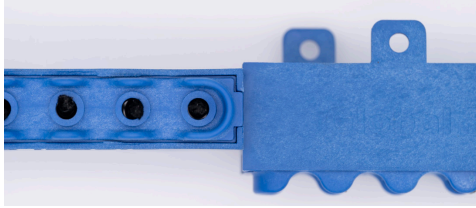

Figure 9A - Screw misaligned



Figure 9B - Screw misaligned

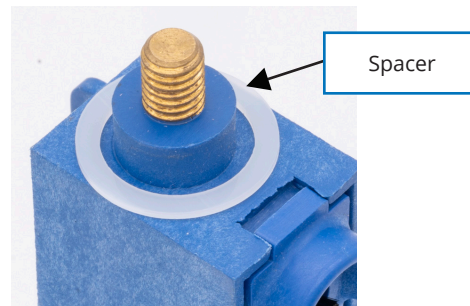

Figure 10

**Step 2** – Once the last iMOD section is added, push the end cap into the receiver end of the last iMOD section. It will “snap” into place with proper pressure. Refer to FIGURE 11A OR 11B as appropriate.

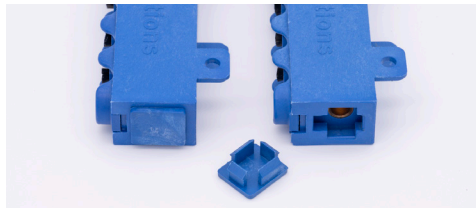

Figure 11A - Snap type

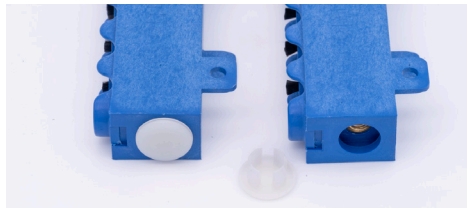

Figure 11B - Screw type

**Step 3** – Verify all iMod sections are engaged and the end cap is installed prior to mounting in the air handler.

**Step 4** – Ensure that the end cap does not touch a grounded AHU/RTU chassis wall. A minimum of 2” clearance from any metallic substrate is required. If necessary, remove one 6” module to shorten the overall length of the bar.



## *iMOD Mounting*

The included magnets shall be used as a spacer even when installing on non-magnetic surfaces. Care should be taken when selecting self tapping screw length to avoid penetrating the cooling coil/tubing.

**Step 1** – The GPS-iMOD modular sections can be mounted using the included magnets and hardware, and/or they can be mounted using sheet metal screws (not provided) through the integral molded brackets. There should be at least one magnet mounted on each end of the bar assembly and depending on length of bar, magnets should be mounted on every third section (roughly 18" spacing between magnets). Refer to FIGURE 12 for examples of top or side magnet mount installations. Screws and nuts are provided by GPS for mounting the magnets to the top or side of the bar.

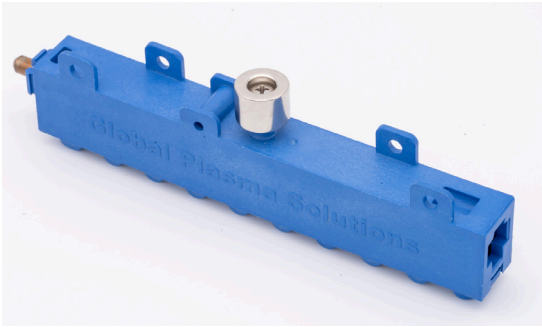

Figure 12A

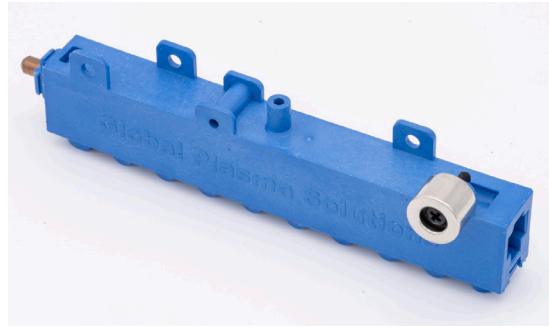

Figure 12B

**Step 2** – When mounting to a non-magnetic 1.5" angle (1/8" thk), magnets should be mounted to the side mounting tabs every 18" and every 36" on top post for spacing purposes. Refer to Figure 13 for spacing layout.

**Step 3** – When mounting the GPS-iMOD, the bottom of the 'Global Plasma Solutions' text shall be level with top of the finned surface area of the coil or the lip of a mounting angle as shown by the dotted lines in FIGURE 13, with the carbon fiber brushes pointing towards the floor of the air handler and perpendicular to the airflow. It is advisable that any bar over 6' long is installed by two people to prevent risk of damage to an unsupported bar.

**NOTE:** Do not fasten iMOD bar direct to mounting surface. The clearance between the mounting surface and the side wall of the bar shall be between 1/8" and 1/2". Using the provided magnets as indicated in Figure 13 will provide the optimal 1/2" spacing. Failure to do so may result in low ion density and poor performance.

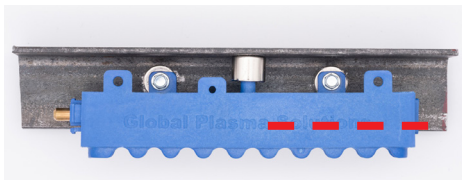

Figure 13A

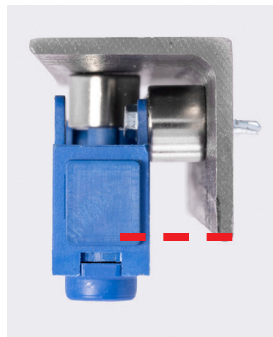

Figure 13B



Figure 13C





Keep all carbon fiber brushes away from any metal (surfaces or pipes/tubes etc.). The ionization bar should always be mounted on the air-entering side of the cooling coil. The GPS-iMOD (SCREW TYPE ONLY) powerhead may be rotated to provide the best power cord routing based on the installation. When more than one bar is required per coil, the bars shall be mounted such that they each cover the same vertical distance (refer to FIGURE 14).

**High Voltage cables shall not be cut or altered in any way. Doing so will void the electrical safety certification and product warranty.**

**Use grommets for any holes or protrusions.**

**High voltage cables should be routed so no bend is less than a 3" bend radius (6" diameter for 180° high voltage cable routing).**

**NOTE:** If mounting multiple bars across the coil or when mounting to coil header has iMOD bar out of the direct path of the air stream, installing contractor will need to provide a piece of 1.5" (1/8" thk) metal angle across the face of the coil to attach the GPS-iMOD bar.

Must mount to coil where possible

**Step 4** – Use a soft cloth with isopropyl alcohol and wipe any debris off the GPS-iMOD outer bar and spaces between needle housings.

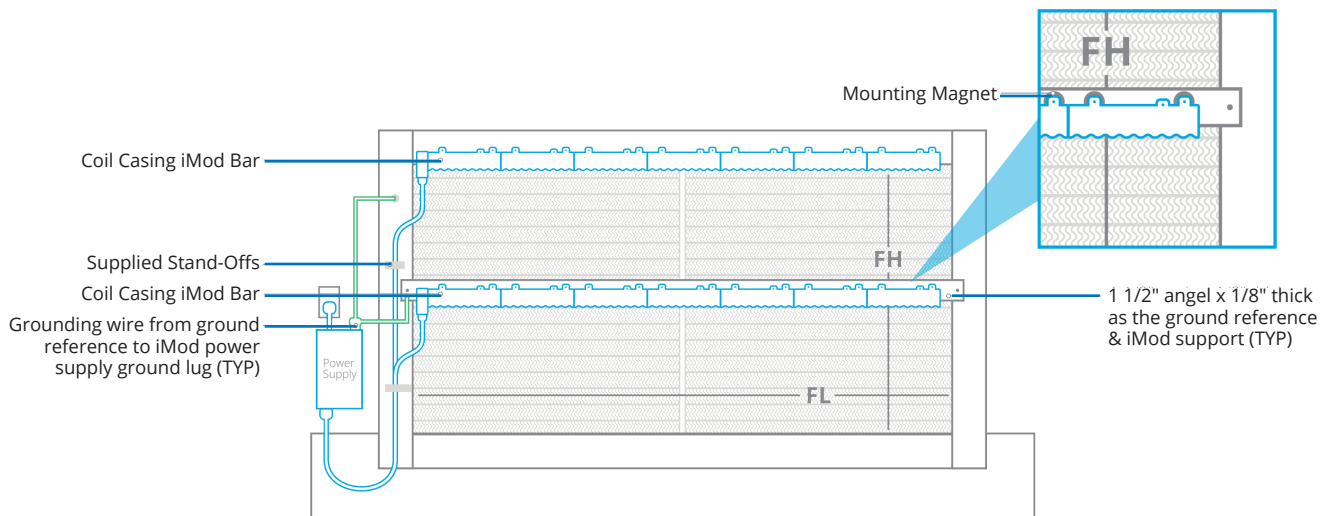

Figure 14



## Connection of GPS-iMOD bars to Power Supply

**WARNING** – The coiling or bundling of high voltage (HV) cables may cause added voltage drop and decreased ion output from the iMod. Installations where the cable(s) are touching in multiple locations will experience reduced output and lifespan.

Please follow appropriate routing of high voltage (HV) cables as indicated below:

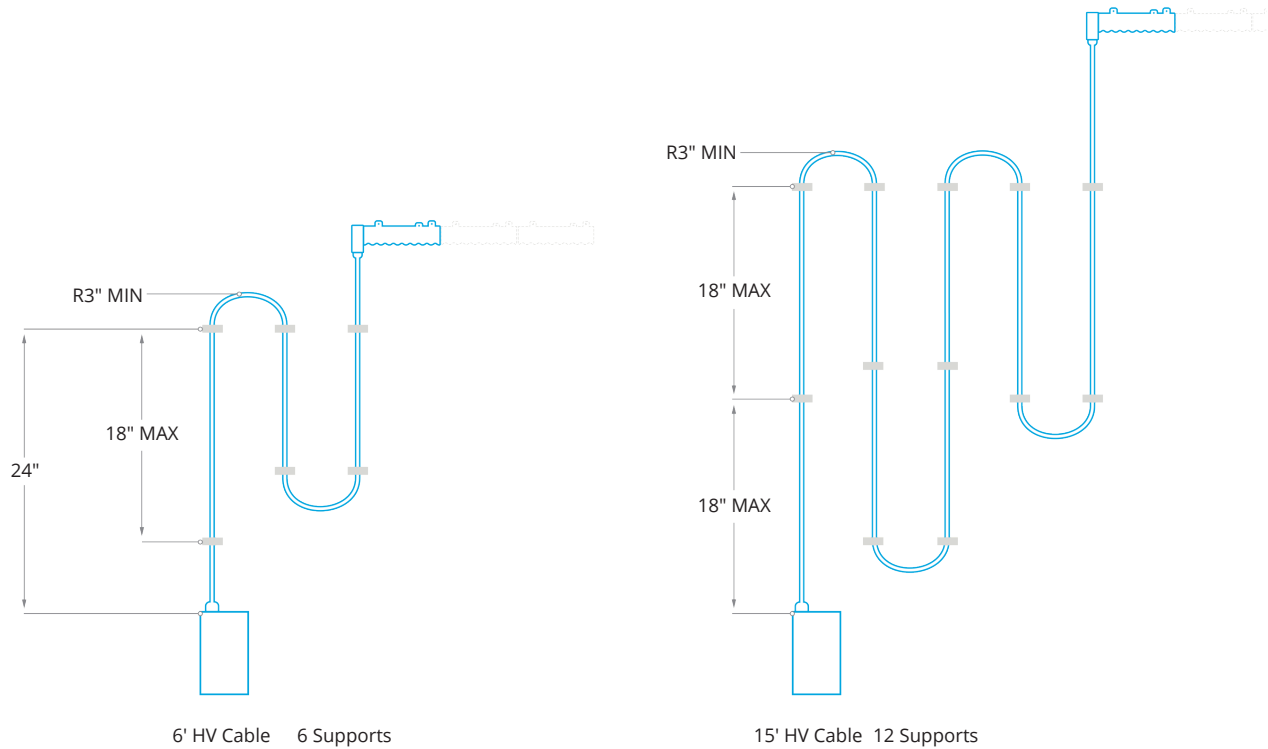

**DO NOT CUT OR ALTER HIGH VOLTAGE CABLES.** Cables 15ft long can be ordered if additional length is required. DO NOT coil, bunch, or loop the cable up so that it comes in contact with itself. To reduce slack in the cable, create long sweeping "S" shapes, like switchbacks in a road. High voltage cable should be routed with soft bends only such as creating long sweeping "S" shapes. Minimum bend radius is 3". Secure the cable(s) so they will not interfere with or be damaged by equipment or personnel.

**NOTE:** When securing high voltage cable to a conductive surface, provided stand-offs shall be used every 18" to prevent high voltage cables from contacting surface.



Supplied stand-off – Typical



## Power Supply Installation and Wiring

**WARNING** – DO NOT CONNECT POWER UNTIL VOLTAGE SELECTOR SWITCH INSIDE HOUSING IS CONFIRMED TO BE IN THE CORRECT POSITION MATCHING THE PRIMARY POWER BEING APPLIED (See FIGURE 15).

Follow all applicable local and national electrical and building codes.

The GPS-iMOD system requires a total of 15 watts to power up to 4 GPS-iMOD bars, regardless of length. The power supply will only accept 24VAC, 110VAC or 208-240VAC at 50HZ or 60HZ.

*NOTE: The power supply has an internal voltage selector switch set to 110VAC from the factory, as shown in FIGURE 15. If 24VAC or 208-240VAC is required, move the selector switch to the proper position as shown on the circuit board or inside cover of the power supply lid. DO NOT APPLY POWER until the switch position matches the power supplied. Based on voltage input or local codes, the 3-prong plug may be cut off and the three wires are as follow:*

*Black = 24V, 110V or 208-240V  
White = Neutral  
Green = Ground.*

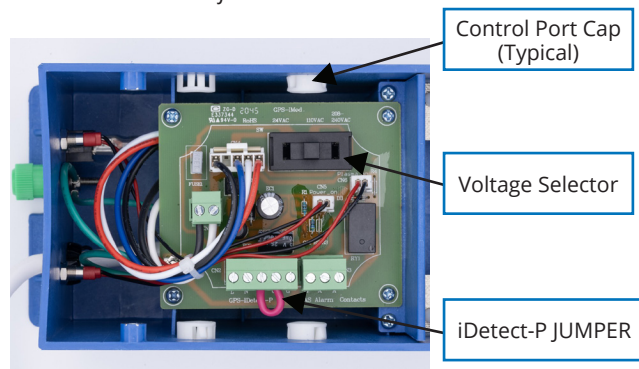

Figure 15

**THE FACTORY ATTACHED POWER CORD MUST BE RETAINED WHERE IT ENTERS THE iMOD POWER SUPPLY HOUSING. REMOVING THIS POWER CORD WILL VOID THE WARRANTY.**

**NOTE:** The power supply must be grounded for all input voltages. If connecting to 24VAC power, the green grounding wire or green grounding lug on the power supply housing must be connected to electrical earth ground. A grounded common will not suffice as adequate power supply grounding.

**Step 1** - The power supply may be mounted to the internal or external wall of the air handler. If the power supply will be exposed to wash down or outdoor elements, it must be enclosed in the Nema 4x enclosure (purchased separately).

**Step 2** - The mounting location selected shall be such that there is a minimum amount of excess HV cable from the iMOD bars, or that excess can be routed as instructed previously in this manual.

**Step 3** - Remove the 4 screws securing the lid of the power supply.

**Step 4** - Mount the power supply to the wall using sheet metal screws through the mounting tabs on the power supply.



**Step 5** - The high voltage (HV) compartment has 6 HV ports. Refer to FIGURE 16. Based on the jobsite specific wiring route, access to the right, left or top side may be desired. Remove the plug from the port desired and fill the port not used with the spare plug. **DO NOT RUN HIGH VOLTAGE CABLES THROUGH THE CONTROL PORTS. DO NOT RUN CONTROL WIRING THROUGH HIGH VOLTAGE (HV) PORTS! REFER TO FIGURE 16.**

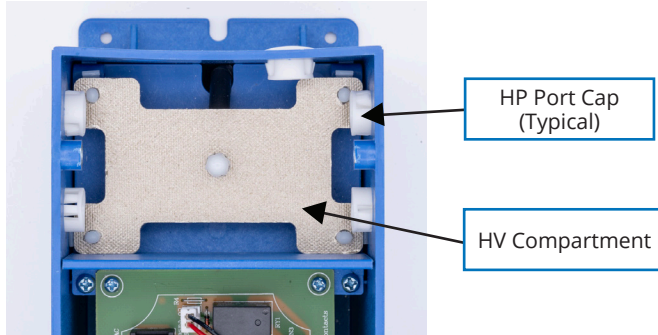

Figure 16

**Step 6** - Remove the plastic cap and top nut from the HV post (FIGURE 17). DO NOT REMOVE THE BOTTOM NUT!



Figure 17

**Step 7** - Remove the plastic nut (FIGURE 18) from the strain relief at the end of the high voltage cable. Next, push the HV wire through the desired port and place the plastic nut back over the strain relief, tightening to secure the HV cable assembly in place. Place the electrical eye connector over the HV post and tighten down the top nut and plastic cap to secure (FIGURE 19). If there are multiple bars connected, place all electrical eye connectors under the top nut prior to tightening. Once all connections are made, replace lid or proceed to connect the control wiring.

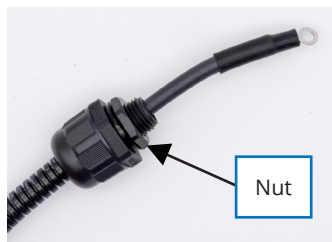

Figure 18



Figure 19A



Figure 19B

**Step 7** - All unused ports must be capped.





### Connection to Building Management System/Building Automation System

The GPS-iMOD has an internal ionization output sensing circuit. The external GPS-iDetect-P is not required but may be installed as an option. Integral alarm “dry” contacts will close when the system is on and operating properly. To tie into the BMS/BAS for remote monitoring, use 18/2 twisted pair, SHIELDED, plenum rated cable and connect to the BMS/BAS ALARM contact terminals. Connect the cable shield to the ground terminal as shown in FIGURE 20. The terminal block may be removed for ease of wiring. **Control wires and high voltage (HC) cables shall be kept separate from each other at ALL times. DO NOT RUN BOTH CABLES TOGETHER AND DO NOT ZIP TIE CONTROL WIRING TO FLEXIBLE HV CABLES! OR iMOD BAR**

### CONNECTING TO GPS-iDETECT-P

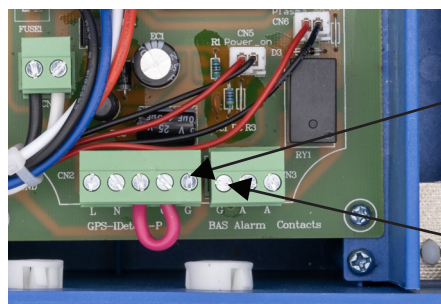

Ground terminal for 18/4 shield on GPS-iDetect-P. Please note, only ground the end of shielded cable inside the power supply! Do not ground both ends of the shielded cable!

Ground terminal for 18/2 shield on BMS/BAS alarm contacts. Please note, only ground the end of shielded cable inside the power supply! Do not ground both ends of the shielded cable!

Figure 20

**Step 1** - Remove the red jumper wire between C and NO on the GPS-iDetect-P terminal block (see FIGURE 15 for jumper wire).

**Step 2** - Using 300V, 18/4, plenum rated, SHIELDED cable wire between the GPS-iDetect-P power and normally open terminals and the GPS-iMOD power supply GPS-iDetect-P terminal block as shown in FIGURE 20. Ground the 18/4 SHIELD to the ground terminal on the GPS-iDetect-P terminal strip shown in FIGURE 20.

**Only ground ONE end of the shielded cable.**

**Do not ground the end connected to the GPS-iDETECT-P sensor.**

**DO NOT RUN WIRING WITH HV CABLES!**

**DO NOT RUN WIRING ALONG iMOD IONIZATION BAR!**

**Step 3** - Mount the GPS-iDetect-P using the included 1” coated pipe clamp and secure to a GPS-iMOD section as shown in FIGURE 21 using a nut and bolt.

**Step 4** - When the GPS-iDetect-P senses output, the “Plasma On” light will illuminate on the front panel of the power supply and the BAS/BMS Alarm Contacts will close. When using the GPS-iDetect-P in conjunction with the GPS-iMOD power supply, always connect to the BMS/BAS using the BMS/BAS Alarm Contacts, not the contacts on the GPS-iDetect-P.



Figure 21



## Operation

**Step 1** - Once the voltage selector switch has been set, all HV wire(s) connected and iMODs mounted, turn the power switch to the "ON" position. When the switch is turned "ON" the "Power ON" light will illuminate, letting the user know power is supplied and the GPS-iMOD system is energized. Note: If a door switch, fan interlock switch or air flow switch are in series with the power, the system may not turn on until all safeties are closed. When power is supplied and the internal or optional remote mounted GPS-iDetect-P is sensing output, the "Plasma On" light will illuminate.

**Step 2** - The internal BAS Alarm Contacts will close proving system operation to the BMS.

**Step 3** - Using a standard non-contact voltage meter, place it near the ion needles and prove there is ion output. An optional ion meter can be purchased from GPS and actual ion output values can be measured. A permanent mount ion detector with BAS interface may be provided as an option for 24/7 output monitoring.

## Product Registration

By registering your order, the standard limited warranty on eligible products from your purchase is automatically extended to 3 years, at no additional cost.

Register your products at [www.gpsair.com/product-registration](http://www.gpsair.com/product-registration) or scan the QR code.



The information provided in this manual is up to date at the time of printing. Any revisions to this document will supersede the content included. For the latest applicable version of this manual, visit our website or utilize the QR code.



## Maintenance

The GPS-iMOD system has been designed for minimum maintenance. Below are steps to help ensure optimal performance and long life:

1. On a QUARTERLY basis, or as often as the filters are changed if more often than quarterly, turn off the power to the GPS-iMOD and swipe the brushes along the iMOD bar with a dry rag to help dislodge and disperse any particles accumulated on the emitters.
2. On an ANNUAL basis:
  - A. Turn off the power to the GPS-iMOD and using isopropyl alcohol and a nylon (wire free) brush to gently clean the iMOD emitter needles.
  - B. With the iMOD still powered off, use a soft cloth with isopropyl alcohol and wipe any debris off the body of the iMOD bar including the spaces between the needle housings.
  - C. Make sure to allow any residual alcohol to evaporate prior to re-powering the iMOD.
  - D. Note: in high contaminant load environments, the iMOD may require more frequent cleaning.



## *Troubleshooting*

1. Ensure that GPS-iMOD start-up document was completed properly.
  
2. Power supply "Power On" light not illuminated when the power switch is in the "ON" position. Check that any third party safety switches are closed and there is primary power applied to the power supply. If light will still not illuminate, remove power and energize after five minutes. The GPS-iMOD system uses an internal auto-reset circuit breaker. Either a voltage surge or high temperature/load condition can trip the circuit breaker. If the "Power On" light is off and the "Plasma On" light is "On," the "Power On" light may have burned out. Contact your local Representative or the GPS factory to have your power supply repaired or replaced.
  
3. No Ionization Output.
  - Confirm the power supply is operating properly per step 1 above.
  - Confirm the HV cables are inserted and secured properly.
  - Confirm the needles are clean and free of debris.
  - Confirm the voltage selector switch is set to the correct voltage input.



3101 Yorkmont Road • Suite 1500  
Charlotte, NC 28208  
980-279-5622

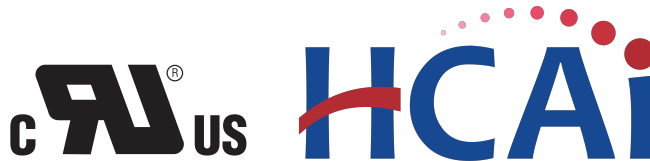
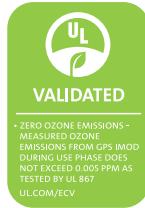

To access a list of applicable patents,  
please visit [www.gpspatents.com](http://www.gpspatents.com)



[gpsair.com](http://gpsair.com)